

Product Cut Sheet: Motorized Shade System

ShadeMonster motorized roller shades are available with either 120-volt AC or 24-volt DC motors. They have been designed to meet both U.S. and European electrical standards. Motors are available in several sizes, speeds, and lift capabilities for use with virtually any size window shade. The motors are fully encapsulated for greater shock resistance, along with quieter operation. The three central components of a roller shade motor are the Limit Switches, which regulate the top and bottom limits of the shade, the Brake designed for maximum strength and durability, and the Gear Mechanism engineered for versatility of lift speed output.

AC Motorized Shade System

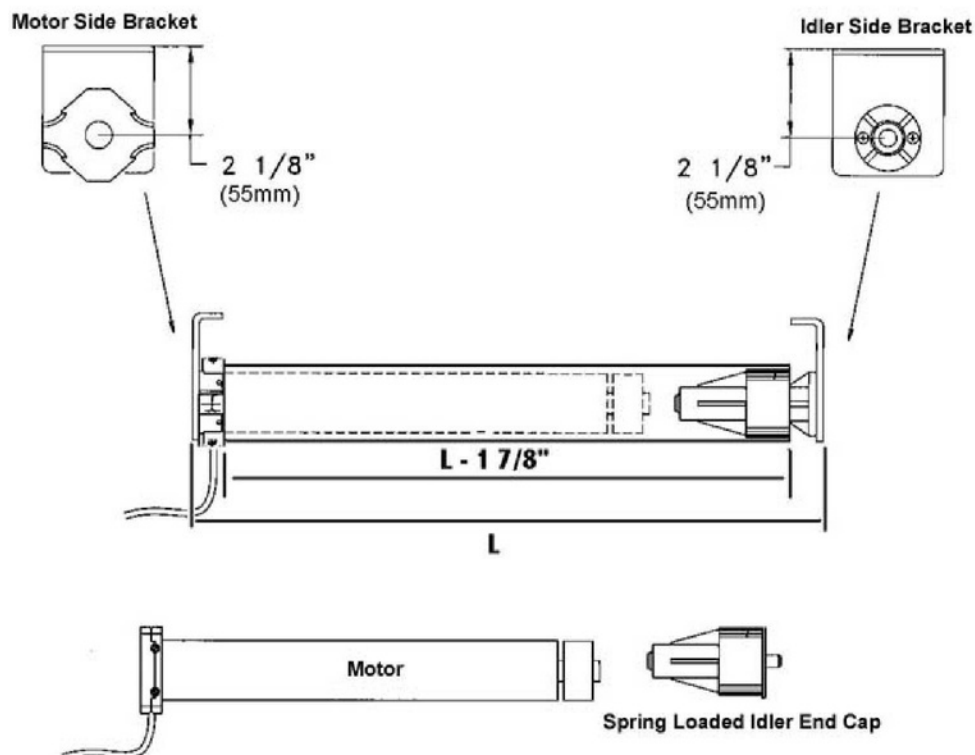

Controlling shade motors can be as simple as using a single wall switch operating one shade or creating fully integrated systems controlling shade motors in groups, sub-groups, and individually by use of:

- Remote control transmitters
- Wall Switches
- 24-hour timers
- Sun sensors
- Building maintenance integration devices

Product Cut Sheet: Motorized Shade System

Motorized Shade System with Aluminum Fascia Valance

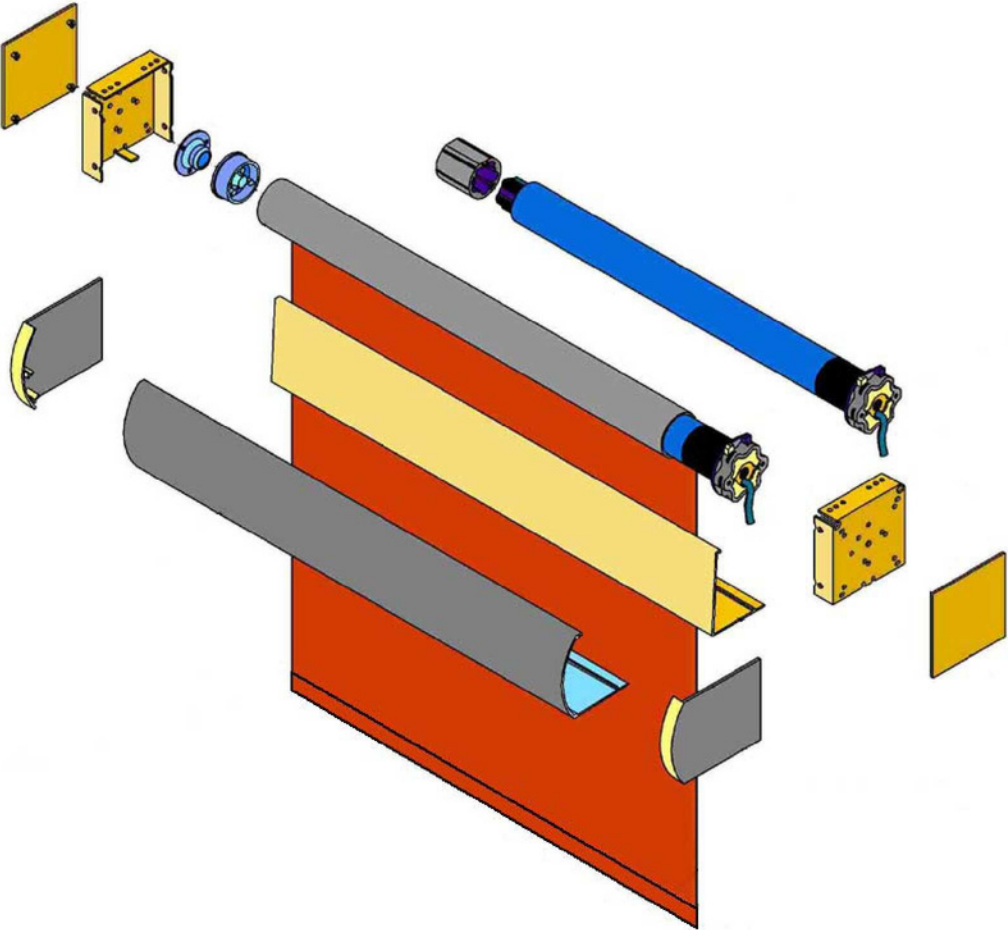

ShadeMonster
255 NE 59th St
Miami, FL 33137

Ph: (866) 206-8056
C: (786) 266-7375
www.shademonster.com

